

Plot Date: 24 October 2023 17:28:56
 File Name: C:\WORKING\60683393\ACM LLO-ZZ-DR-LR-0092\60683393-ACM LLO-ZZ-DR-LR-0092.dwg

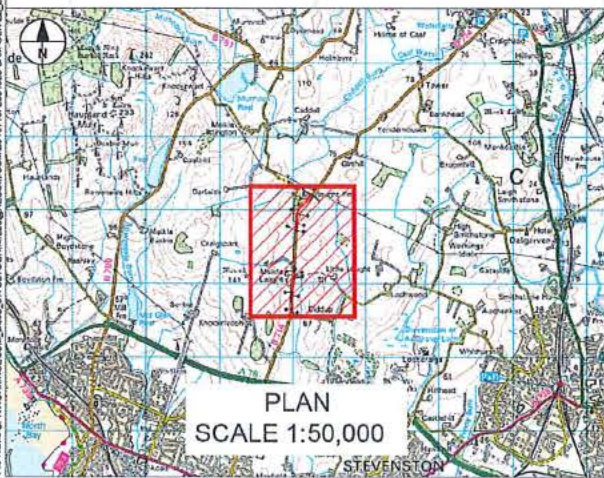

SAFETY, HEALTH AND ENVIRONMENTAL INFORMATION BOX

IT IS ASSUMED THAT ALL WORKS ON THIS DRAWING WILL BE CARRIED OUT BY A COMPETENT CONTRACTOR WORKING WHERE APPROPRIATE TO AN APPROPRIATE METHOD STATEMENT.

THIS DRAWING IS TO BE USED ONLY FOR THE PURPOSE OF ISSUE THAT IT WAS ISSUED FOR AND IS SUBJECT TO AMENDMENT.

EXCEPTIONAL RISKS RELATING TO THE WORKS ASSOCIATED WITH THIS DRAWING ARE IDENTIFIED BELOW.

NOTES

1. THIS DRAWING IS TO BE READ IN CONJUNCTION WITH ALL OTHER RELEVANT DOCUMENTATION.
2. DO NOT SCALE FROM THIS DRAWING, USE ONLY PRINTED DIMENSIONS.
3. ALL DIMENSIONS IN MILLIMETRES, ALL CHAINAGES, LEVELS AND COORDINATES ARE IN METRES UNLESS DEFINED OTHERWISE.
4. THIS DRAWING IS TO BE READ IN CONJUNCTION WITH THE PROJECT HEALTH & SAFETY FILE FOR ANY IDENTIFIED POTENTIAL RISKS.
5. PLOT IDS HAVE BEEN ADDED ONLY FOR EASE OF REFERENCE BETWEEN PLOTS.
6. LAND OWNERSHIP INFORMATION BASED ON INDICATIVE PLANS OBTAINED FROM LAND REGISTRY.

LEGEND

- PLOT NUMBER
- LAND TO BE ACQUIRED
- SERVITUDE RIGHT TO BE ACQUIRED

FOR INFORMATION	By	Date	Subj
		25/07/23	P02.1

REVISION DETAILS

INITIAL STATUS OR WIP
Client

Project Title



B714 Upgrade

COMPULSORY PURCHASE ORDER 1 PLANS SHEET 1 OF 4

Design	Drawn	Checked	Approved	Date
60683393				

Scale @ A1
1:2500

Internal Project No. 60683393
Suitability SO

Land Ownership Boundaries

THIS DOCUMENT HAS BEEN PREPARED PURSUANT TO AND IS SUBJECT TO THE TERMS OF AECOM'S APPOINTMENT BY ITS CLIENT. AECOM ACCEPTS NO LIABILITY FOR ANY USE OF THIS DOCUMENT OTHER THAN BY ITS ORIGINAL CLIENT OR FOLLOWING AECOM'S EXPRESS AGREEMENT TO SUCH USE, AND ONLY FOR THE PURPOSES FOR WHICH IT WAS PREPARED AND PROVIDED.



AECOM
Aurora (1st Floor)
130 Buchanan Street
Glasgow
Tel: +44 (0) 141 249 0200
www.aecom.com

Drawing Number	Project / Work Package	Originator	Volume	File
60683393	-ACM	-LLO -	P02.1	

Location	Type	Rule	Number
ZZ	-DR	-LR	-0096

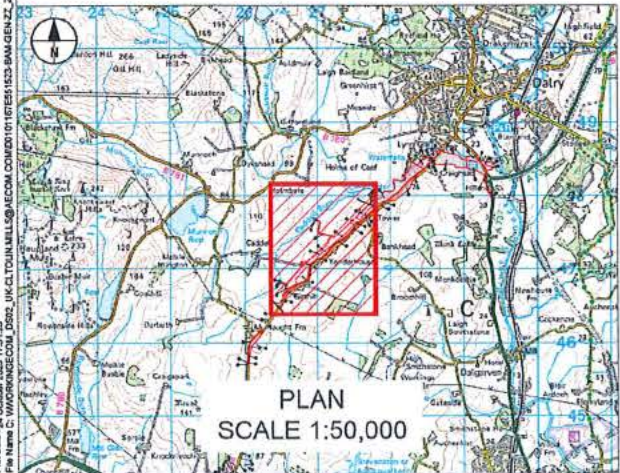
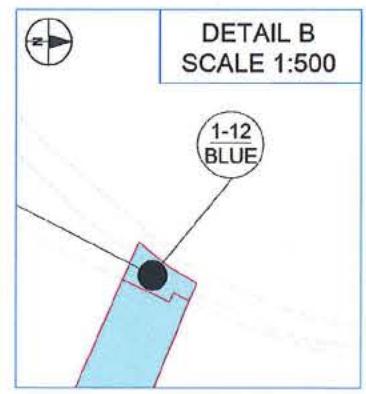
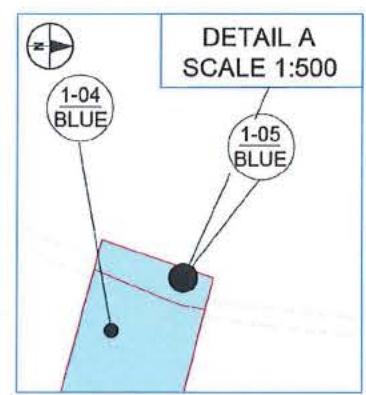
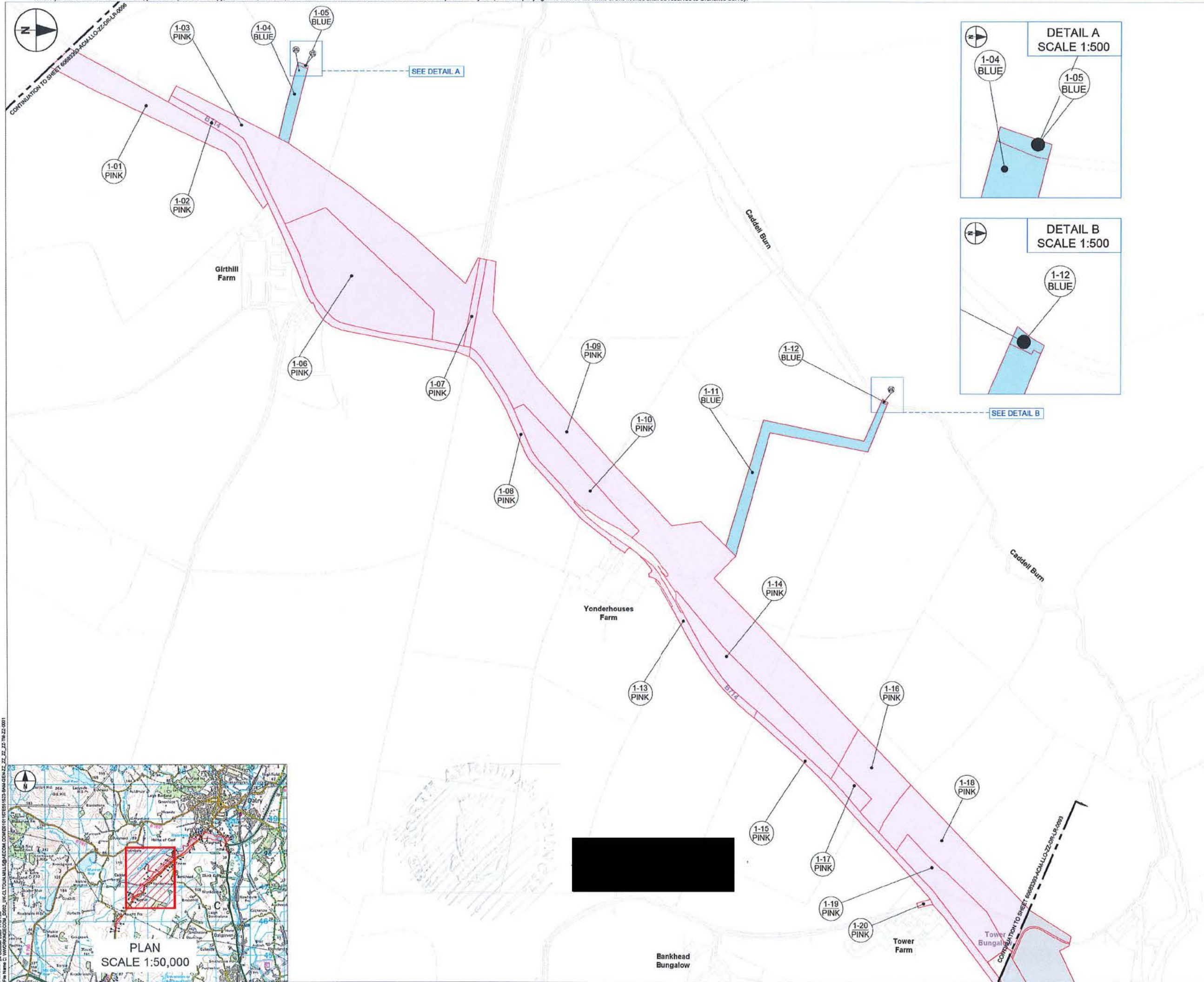

SAFETY, HEALTH AND ENVIRONMENTAL INFORMATION BOX

IT IS ASSUMED THAT ALL WORKS ON THIS DRAWING WILL BE CARRIED OUT BY A COMPETENT CONTRACTOR WORKING WHERE APPROPRIATE, TO AN APPROPRIATE METHOD STATEMENT. THIS DRAWING IS TO BE USED ONLY FOR THE PURPOSE OF ISSUE THAT IT WAS ISSUED FOR AND IS SUBJECT TO AMENDMENT.

EXCEPTIONAL RISKS RELATING TO THE WORKS ASSOCIATED WITH THIS DRAWING ARE IDENTIFIED BELOW.

NOTES

1. THIS DRAWING IS TO BE READ IN CONJUNCTION WITH ALL OTHER RELEVANT DOCUMENTATION.
2. DO NOT SCALE FROM THIS DRAWING, USE ONLY PRINTED DIMENSIONS.
3. ALL DIMENSIONS IN MILLIMETRES. ALL CHANGES, LEVELS AND COORDINATES ARE IN METRES UNLESS DEFINED OTHERWISE.
4. THIS DRAWING IS TO BE READ IN CONJUNCTION WITH THE PROJECT HEALTH & SAFETY FILE FOR ANY IDENTIFIED POTENTIAL RISKS.
5. PLOT IDS HAVE BEEN ADDED ONLY FOR EASE OF REFERENCE BETWEEN PLOTS.
6. LAND OWNERSHIP INFORMATION BASED ON INDICATIVE PLANS OBTAINED FROM LAND REGISTRY.

LEGEND

PLOT NUMBER

LAND TO BE ACQUIRED

SERVITUDE RIGHT TO BE ACQUIRED

ISSUED TO	MS	Date	Staff
ISSUED TO IAC	MS	01/09/23	P02
		01/09/23	P03.1

REVISION DETAILS

By	Check	Date	Staff

INITIAL STATUS OR WIP

Client

Project Title **B714 Upgrade**

COMPULSORY PURCHASE ORDER 1 PLANS SHEET 2 OF 4

Designed	Drawn	Checked	Approved	Date

Internal Project No. 60683393
 Scale @ A1 1:2500
 Substation SO
 Volume Land Ownership Boundaries

AECOM

AECOM
 2nd Floor
 177 Bithwell Street
 Glasgow
 Tel: +44 (0)141 262 0500
 www.aecom.com

Drawing Number	Project / Work Package	Originator	Volume	Rev
60683393	-ACM	-LLO	-	P03.1
ZZ		-DR-LR	-0092	

Location I Type I Rule I Number



Bankhead Bungalow

Bankhead Farm

Tower Farm

2-02 PINK

CONTINUATION TO SHEET 60683393-ACM-LLO-ZZ-DR-LR-0094

2-03 PINK

2-01 PINK

2-04 PINK

2-05 PINK

2-06 PINK

2-07 PINK

2-07 PINK

2-08 PINK

2-09 PINK

2-12 PINK

2-13 PINK

2-14 PINK

2-15 PINK

2-10 PINK

2-11 PINK

2-16 PINK

2-17 PINK

2-18 BLUE

SEE DETAIL A

Craigmill

Castlehead Stables

Craighead Farm

Boll Burn

Carr Water

Kilwinning Road

CONTINUATION TO SHEET 60683393-ACM-LLO-ZZ-DR-LR-0094

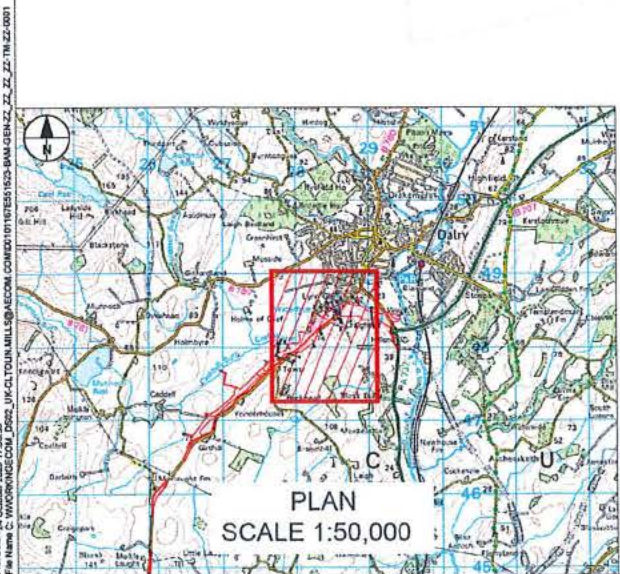
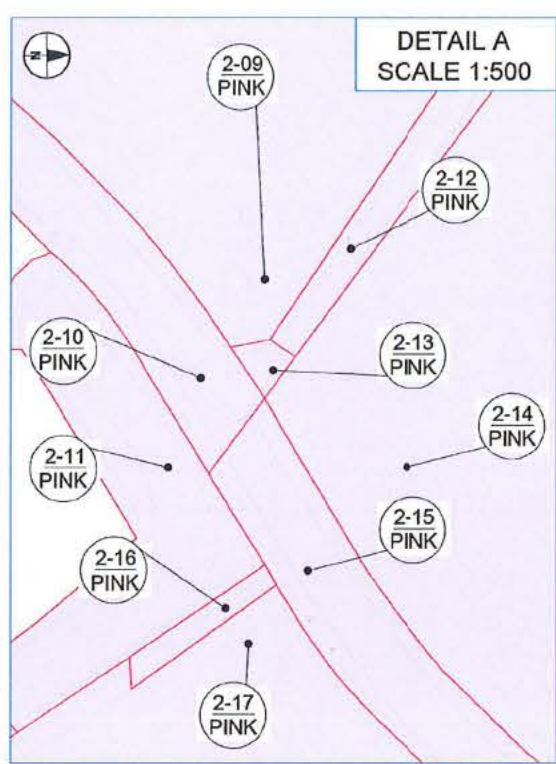

SAFETY, HEALTH AND ENVIRONMENTAL INFORMATION BOX

IT IS ASSUMED THAT ALL WORKS ON THIS DRAWING WILL BE CARRIED OUT BY A COMPETENT CONTRACTOR WORKING, WHERE APPROPRIATE, TO AN APPROPRIATE METHOD STATEMENT.
THIS DRAWING IS TO BE USED ONLY FOR THE PURPOSE OF ISSUE THAT IT WAS ISSUED FOR AND IS SUBJECT TO AMENDMENT.
EXCEPTIONAL RISKS RELATING TO THE WORKS ASSOCIATED WITH THIS DRAWING ARE IDENTIFIED BELOW.

NOTES

- THIS DRAWING IS TO BE READ IN CONJUNCTION WITH ALL OTHER RELEVANT DOCUMENTATION.
- DO NOT SCALE FROM THIS DRAWING, USE ONLY PRINTED DIMENSIONS.
- ALL DIMENSIONS IN MILLIMETRES, ALL CHAINAGES, LEVELS AND COORDINATES ARE IN METRES UNLESS DEFINED OTHERWISE.
- THIS DRAWING IS TO BE READ IN CONJUNCTION WITH THE PROJECT HEALTH & SAFETY FILE FOR ANY IDENTIFIED POTENTIAL RISKS.
- PLOT IDS HAVE BEEN ADDED ONLY FOR EASE OF REFERENCE BETWEEN PLOTS.
- LAND OWNERSHIP INFORMATION BASED ON INDICATIVE PLANS OBTAINED FROM LAND REGISTRY.

LEGEND

2-XX PINK PLOT NUMBER

PINK LAND TO BE ACQUIRED

BLUE SERVICITUDE RIGHT TO BE ACQUIRED

ISSUED TO	MS	DATE	BY
NAC	MS	01/09/23	P02
REVISION DETAILS	By	Check	Date

INITIAL STATUS OR WIP

Client:

Project Title: **B714 Upgrade**

COMPULSORY PURCHASE ORDER 1 PLANS SHEET 3 OF 4

Design	Drawn	Checked	Approved	Date
Internet Project No. 60683393	Subsidiary SO	Scale @ A1 1:2500	Volume	Land Ownership Boundaries

THIS DOCUMENT HAS BEEN PREPARED PURSUANT TO AND SUBJECT TO THE TERMS OF AECOM'S APPOINTMENT BY ITS CLIENT. AECOM ACCEPTS NO LIABILITY FOR ANY USE OF THIS DOCUMENT OTHER THAN BY ITS ORIGINAL CLIENT OR FOLLOWING AECOM'S EXPRESS AGREEMENT TO SUCH USE, AND ONLY FOR THE PURPOSES FOR WHICH IT WAS PREPARED AND PROVIDED.



Designing Number	Project / Work Package	Originator	Volume	Rev
60683393	-ACM-	-LLO-	1	P03.1
ZZ	-DR-LR-	0093		

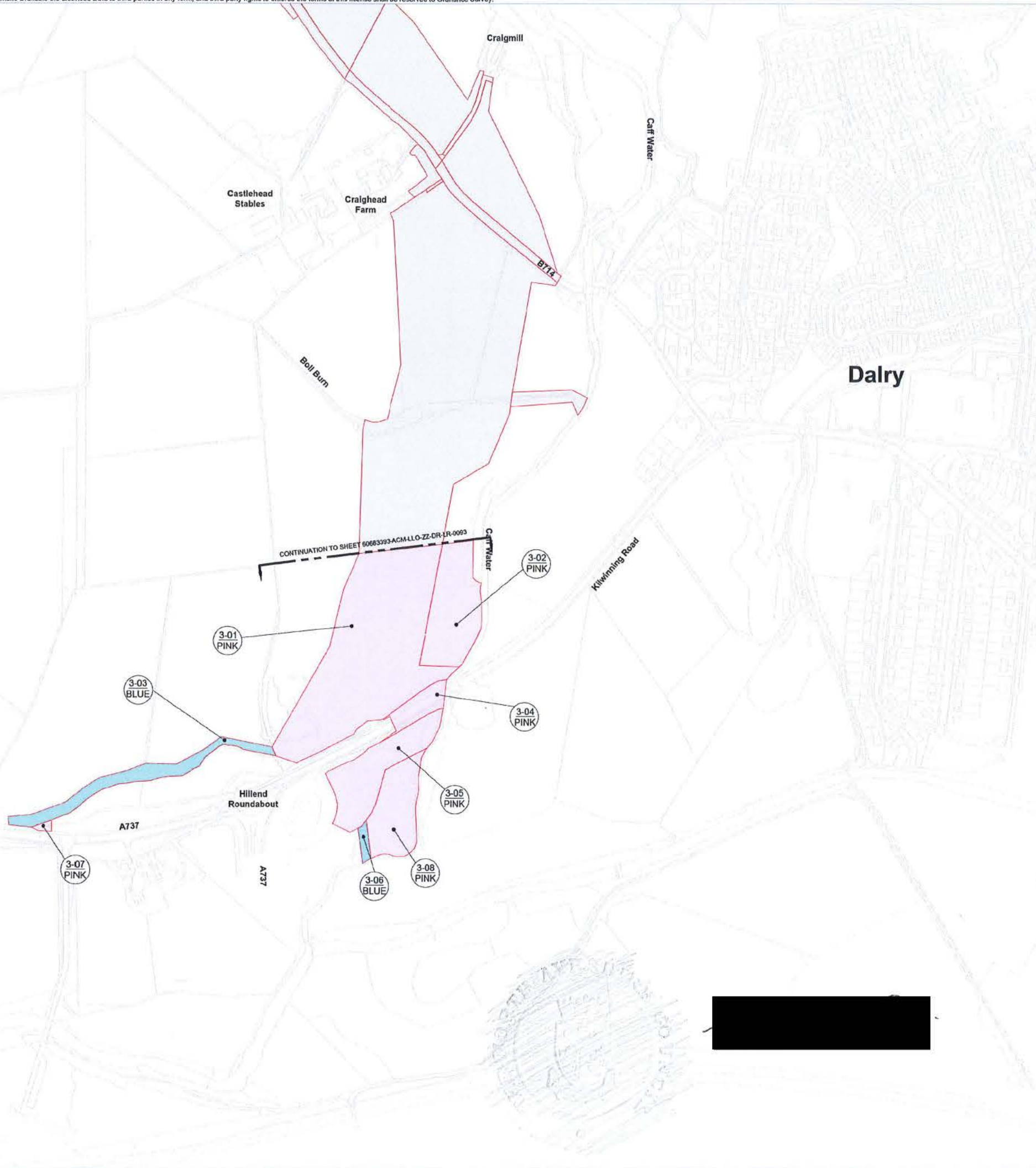

Per Date: 24 October 2023 16:17:33
 File Path: \\AECOM\Projects\60683393\ACM\LL0-ZZ-DR-LR-0094\Drawings\01\60683393-ACM-LL0-ZZ-DR-LR-0094-01.dwg
 Plot Size: 297mm x 420mm
 Plot Scale: 1:50,000
 Plot Title: PLAN SCALE 1:50,000
 Plot Number: 1621

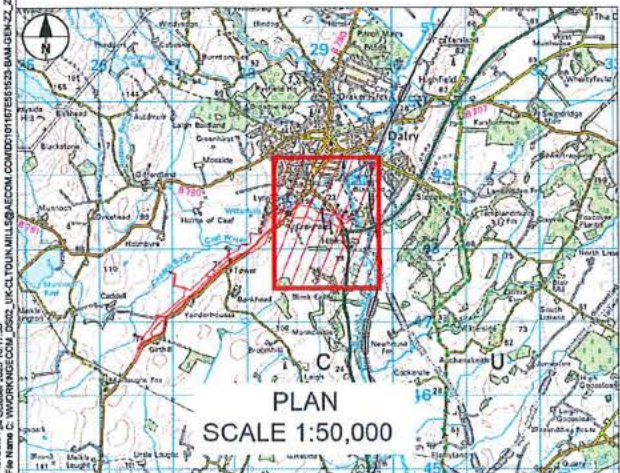

SAFETY, HEALTH AND ENVIRONMENTAL INFORMATION BOX

IT IS ASSUMED THAT ALL WORKS ON THIS DRAWING WILL BE CARRIED OUT BY A COMPETENT CONTRACTOR WORKING WHERE APPROPRIATE, TO AN APPROPRIATE METHOD STATEMENT.
 THIS DRAWING IS TO BE USED ONLY FOR THE PURPOSE OF ISSUE THAT IT WAS ISSUED FOR AND IS SUBJECT TO AMENDMENT.
 EXCEPTIONAL RISKS RELATING TO THE WORKS ASSOCIATED WITH THIS DRAWING ARE IDENTIFIED BELOW.

- NOTES**
1. THIS DRAWING IS TO BE READ IN CONJUNCTION WITH ALL OTHER RELEVANT DOCUMENTATION.
 2. DO NOT SCALE FROM THIS DRAWING, USE ONLY PRINTED DIMENSIONS.
 3. ALL DIMENSIONS IN MILLIMETRES, ALL CHANGES, LEVELS AND COORDINATES ARE IN METRES UNLESS DEFINED OTHERWISE.
 4. THIS DRAWING IS TO BE READ IN CONJUNCTION WITH THE PROJECT HEALTH & SAFETY FILE FOR ANY IDENTIFIED POTENTIAL RISKS.
 5. PLOT ID'S HAVE BEEN ADDED ONLY FOR EASE OF REFERENCE BETWEEN PLOTS.
 6. LAND OWNERSHIP INFORMATION BASED ON INDICATIVE PLANS OBTAINED FROM LAND REGISTRY.

LEGEND

- PLOT NUMBER
- LAND TO BE ACQUIRED
- SERVITUDE RIGHT TO BE ACQUIRED

ISSUED TO NAC:	MS	01/09/23	P02
REVISION DETAILS	By	Date	Scale
	Check		

INITIAL STATUS OR WIP

Client:

Project Title: **B714 Upgrade**

COMPULSORY PURCHASE ORDER 1 PLANS SHEET 4 OF 4

Designed	Drawn	Checked	Approved	Date
Internal Project No: 60683393		Sustainability: SD		
Scale @ A1: 1:2500		Volume: Land Ownership Boundaries		



AECOM
 2nd Floor
 117 Buccleuch Street
 Glasgow
 Tel +44 (0)141 202 0500
 www.aecom.com

Drawing Number: 60683393	Project Work Package: -ACM	1 Originator: -LLO	1 Volume: -DR-LR-0094	Rev: P03.1
ZZ				